

GUNITE Disc Wheel Hubs

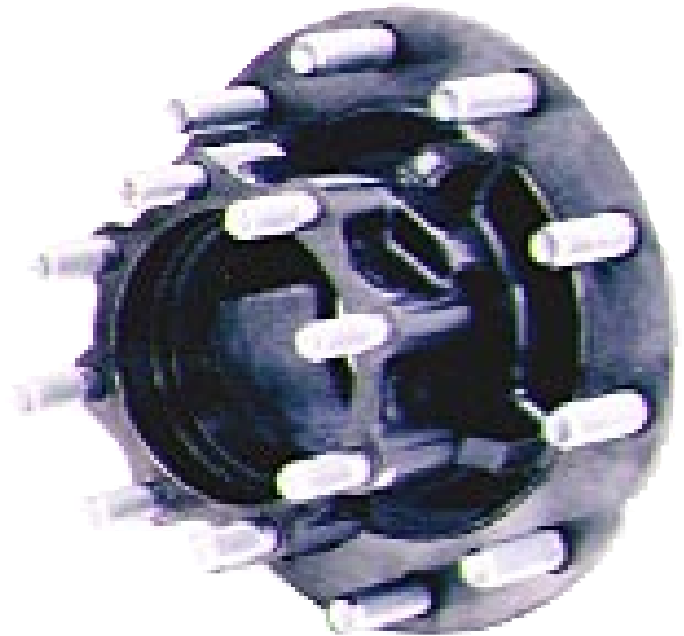

*Maintenance &
Installation Manual*

GUNITE[®]
CORPORATION

Gunite® offers a complete line of traditional ferrous disc wheel hubs for all of today's heavy-duty axle applications. In addition, Gunite offers a line of light-weight cast iron hubs which provide the advantage of substantial weight savings, combined with rugged dependability and maximum operating efficiency.

Like all Gunite products, Gunite disc wheel hubs are designed and tested to meet stringent industry standards for quality and performance. That's why Gunite offers one of the best warranties in the industry.

Typical Hub Mounting Configurations

Gunite disc wheel hubs are available in a wide range of designs to accommodate all common wheel and brake drum mounting configurations. Each hub style is designed so that the machined face of the hub automatically provides proper alignment of wheels and brake drums during installation.

Flange dimensions are carefully controlled in relation to the bolt circle for optimum component contact and support for the wheel. Therefore, it is recommended that *NO* bosses or scallops be used on the outside face of the wheel flange. Their use will substantially reduce wheel life.

Single Flange Nut

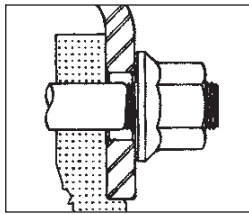

Single

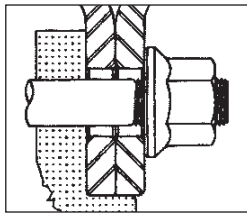

Dual

2 pc Flange Nut Steel

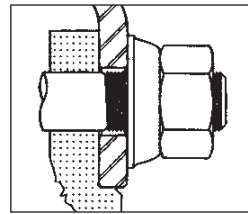

Single 1-1/8-16

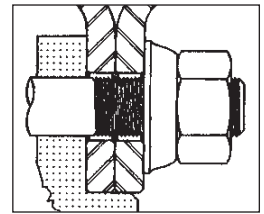

Dual

Ball Seat Steel

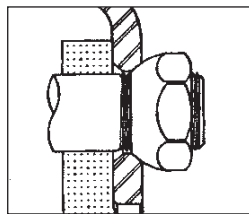

Single 1-1/8-16

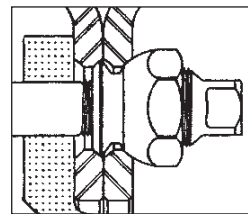

Dual

Ball Seat Aluminum

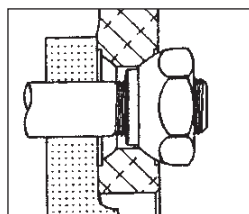

Single 3/4-13

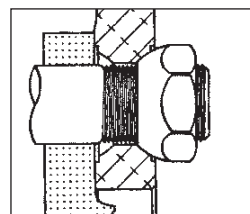

Single 1-1/8-16

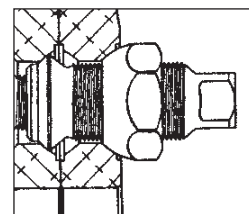

Dual

Hub Mounting Configurations

Gunite hubs are designed for mounting “fixed rim” wheels. This kind of mounting is recognized in the industry as the simplest, strongest, and most effective. It provides for positive torque transfer through the compression of all the mating surfaces, which are held in place with studs and cap nuts.

Gunite offers a full range of hubs designed for either inboard or outboard mounted wheel-end assemblies for front, drive and trailer axles.

Outboard Mounting

In this assembly configuration, the brake drum is mounted on the outboard face of the hub, fitting over the wheel studs. Outboard mounting allows the brakes to be serviced without the removal of the hub, bearings and oil seal, which significantly reduces downtime during regular brake inspection and service.

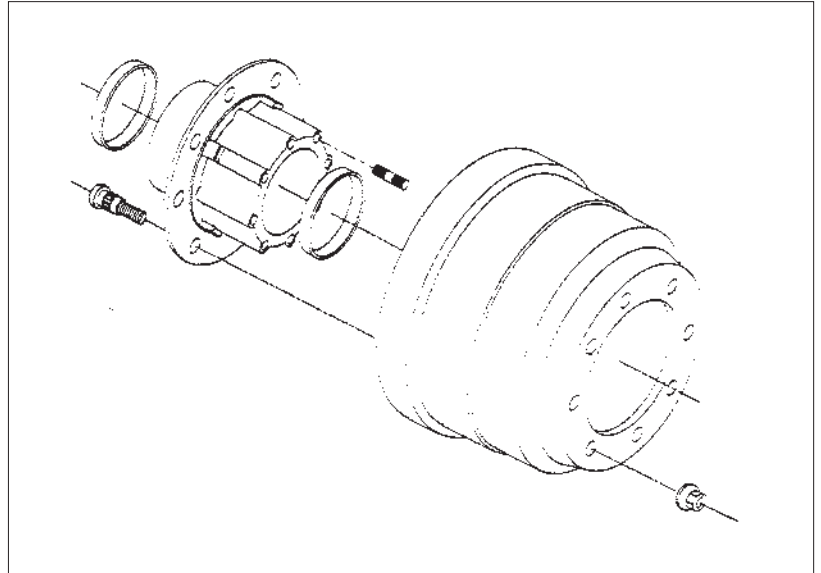

Outboard mounted hub and drum assembly.

Inboard Mounting

Disc brake rotors and inboard design brake drums are mounted on the inboard side of the hub flange and held in place by the wheel studs. On double-flange hubs, which are always mounted inboard, a separate set of bolts are used.

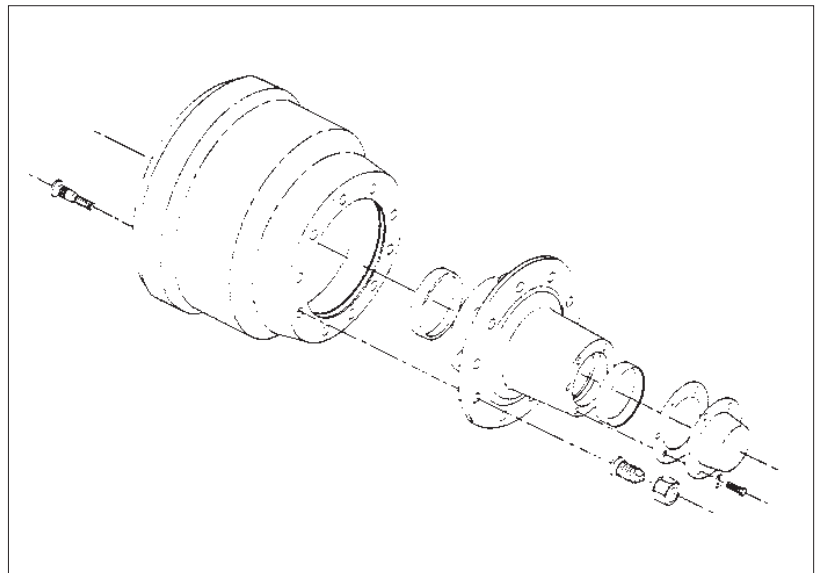

Inboard mounted hub and drum assembly.

Hub Piloted vs Ball Seat Drums

It is important to make sure that the correct hub and drum combination is used when replacing wheel-end assemblies. Incorrect or mismatched parts may result in loose or broken mounting studs or wheel-ends which can result in an accident. If you are unsure about the correct combination for your application, contact the manufacturer for the correct part numbers and styles.

Older ball seat mountings have a close fit between the drum stud holes and stud diameter. The drum is piloted on the hub pilot. The wheels are piloted on the studs using inner and outer cap nuts. (see Figure 1)

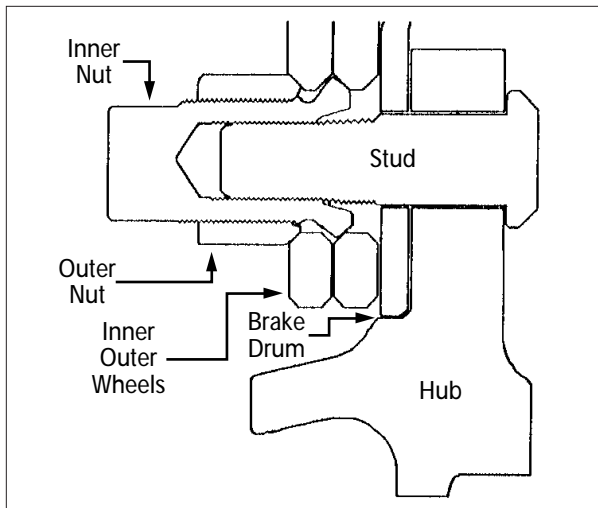

Figure 1 - A ball seat disc wheel mount

Hub piloted mountings have a close fit between the drum pilot and the machined pilot (continuous or interrupted) on the hub. The drum bolt mounting holes are larger than the stud diameter. The wheels and drum are piloted on the hub. (see Figure 2)

New drum designs will allow you to use the same drum for ball seat and hub piloted applications when matched with the proper hub. These new drums cannot be used with older hubs which have a different pilot diameter. Matching the drums with the proper hub is critical in providing and maintaining the support of the wheel-end.

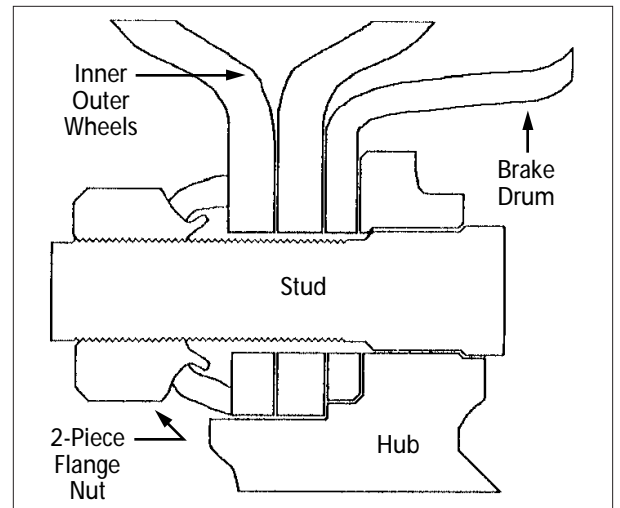

Figure 2 - A hub piloted disc wheel mount.

Mounting Gunitite Brake Drums on "Hub Piloted" Wheel-end Assembly

Gunitite drums are designed with different pilot chamfers where the drum fits the pilot. If corrosion builds up behind the chamfer (point "X" in Figure 3) and a drum with a smaller chamfer (point "Y" in Figure 3) is installed without removing the corrosion from the hub, the drum will not set properly and the mounting flange may break when the

assembly is torqued. Therefore, it is necessary that you thoroughly clean the hub mounting surface using a scraper and wire brush before attempting to mount a new brake drum. *This is especially important if you are mounting brake drums on a wheel-end assembly using an aluminum hub.*

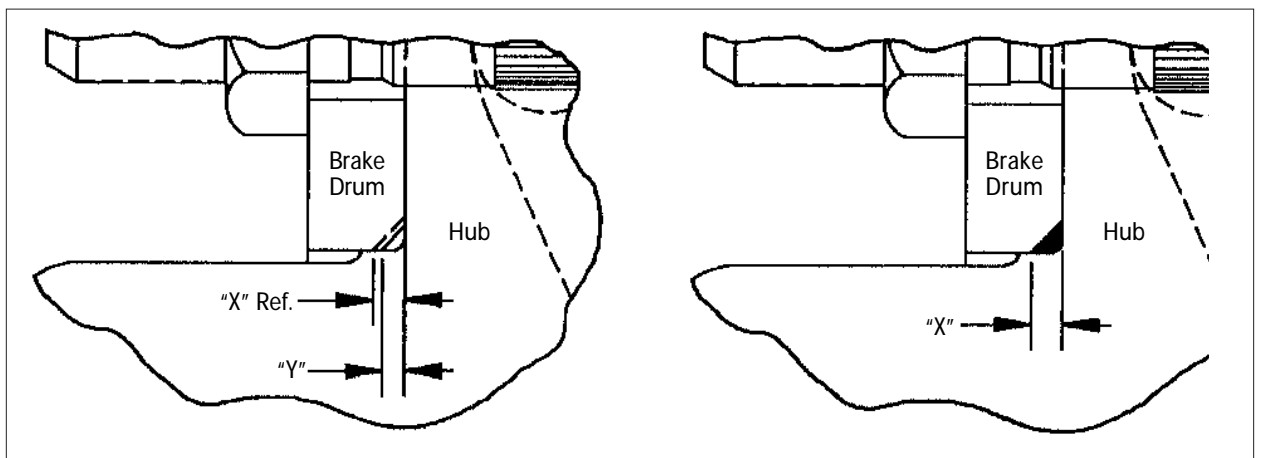

Figure 3 - A Hub Pilot chamfer

When and How to Inspect Disc Wheel Hubs

Regular and thorough inspection of disc wheel hubs should be included in your routine preventative maintenance program. Combined with proper, periodic maintenance, this will help to provide safe and dependable service while avoiding field service problems and eliminate the associated downtime.

While there are no set schedules for the inspection and maintenance of disc wheel hubs, many factors affect the performance and need for service. It is, therefore, advisable to inspect and perform any required repairs each time the tire inflation is checked. The disc wheel hubs should also be thoroughly inspected for potential problems at the time of each tire change.

The hub/wheel assembly should be immediately and thoroughly inspected if an operator complains of wheel shimmy, tire kissing or excessive vibration.

Following are ten of the most common problems encountered and how they can be solved during routine maintenance of disc wheel hub.



FOREIGN MATTER

Grease, dirt, burrs, rust, paint and corrosion will adversely affect the hub's support of the wheel and can be a signal of more serious problems with the wheel-end assembly. Using a wire brush, clean all of the machined surfaces of the hub, stud threads and ball seats. If the wire brush does not remove the foreign matter, the hub should be replaced.

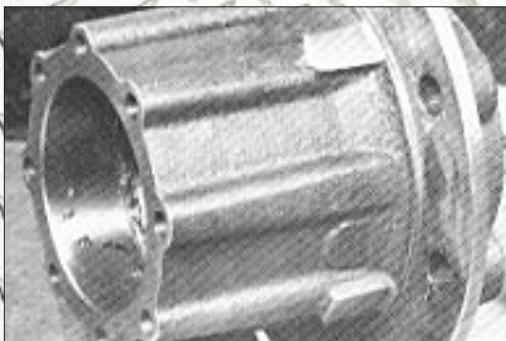

WORN STUD HOLES

This condition is caused by the studs turning in the hole because of insufficient torque on the back nut. If this condition exists, the hub *MUST* be replaced immediately.

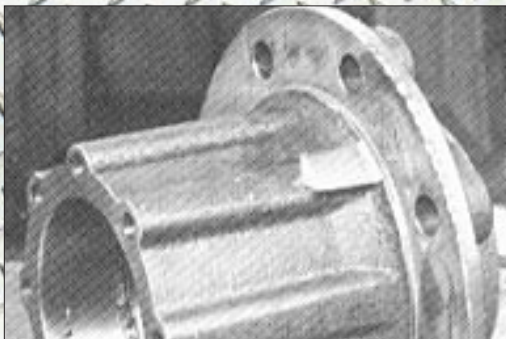

WORN OR DAMAGED MOUNTING FACE

This condition is commonly caused by a loose wheel assembly or improperly installed outboard mounted drum. If the wheel assembly and/or drum is not properly installed, excessive wear will appear on the mounting face of the hub. If this condition exists, the hub *MUST* be replaced immediately (see Proper Installation Procedures - page 8). It is important that the proper torque levels are used and proper torquing procedures are followed when installing the new hub.

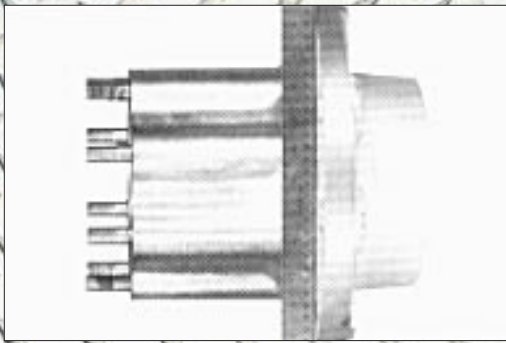

BENT HUB FACE

Distortion or bending of the hub mounting flange can be caused by wheels running loose for an extended period. The most common symptom of this problem are wheel nuts which are consistently loose and require continual re-tightening. To check a hub for this condition, simply place a straight edge across the mounting flange as shown in the photo. If a gap of more than 1/32" exists at any point between the straight edge and the outer diameter of the mounting flange, the hub *MUST* be replaced immediately (see Proper Installation Procedures - page 8).

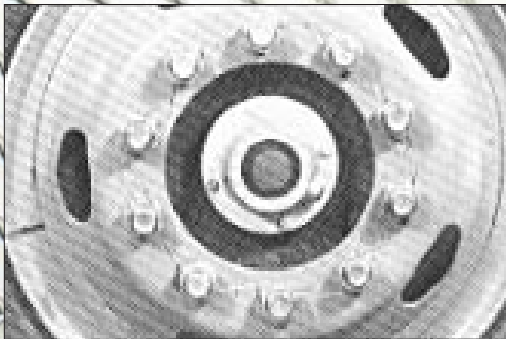

CRACKED WHEELS

This condition can be identified by the development of cracks which appear on the face of the wheel and run between bolt holes or between bolt holes and hand holes or between bolt holes and center hole at one or more places around the wheel. Common causes of this condition may include loose wheel nuts, improper installation procedure (torque), a worn or damaged mounting surface on the hub, loose or broken studs, or a worn stud groove.

The wheel *MUST* be replaced immediately. The hub should be carefully inspected for excessive wear or damage to the mounting surface and/or studs. If the hub or other components are damaged, they *MUST* also be replaced immediately (see Proper Installation Procedures - page 8).

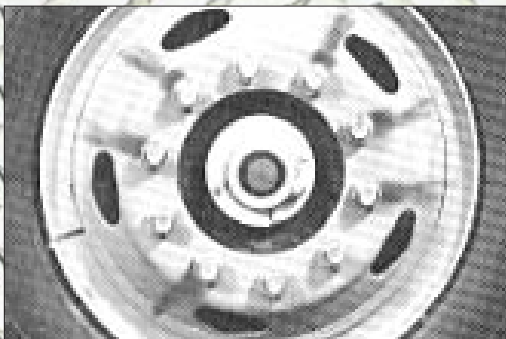

RUST STREAKS

This condition is identified by the appearance of rust streaks radiating from the bolt holes on the wheel. This condition is the result of loose cap nuts and requires immediate service. The entire assembly, including the hub and studs, should be checked for damage as a result of the loose running condition. Any worn or damaged parts *MUST* be replaced immediately (see Proper Installation Procedures - page 8).

LOOSE DRUM OR ROTOR

When a brake drum or rotor is found to be loose during regular inspection, the studs should be checked to make sure they are not too long for the application. The back jam nut must also be checked to make sure that it is firmly seated against the drum or rotor. If the studs are too long for the application or damaged, they *MUST* be replaced immediately, making sure that the proper length studs are installed. Follow the stud installation procedure under Broken Studs - page 7.

LOOSE INNER WHEEL

If the inner wheel is found to be loose during routine inspection, the mounting studs should be checked for excessive stud "standout" beyond the hub mounting face. Excessive stud standout permits the inner nut to bottom out before it properly secures the wheel to the hub mounting surface. If this condition exists, the studs *MUST* be replaced immediately, using studs with the correct body length or "standout". Follow the stud installation procedure under Broken Studs - page 7.

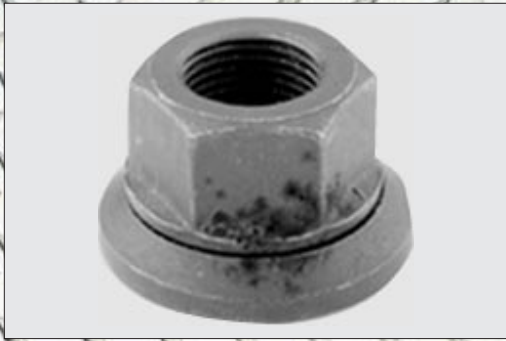

SEIZED OR "FROZEN" TWO PIECE FLANGE NUTS

This problem is indicated when the flange no longer turns on the nut. The cause of this problem can be the result of one or more factors such as corrosion, prolonged use, paint or lack of lubrication between the nut and the flange. If this condition occurs, the nut *MUST* be replaced with the correct two piece flange nut.

When installing the new flange nut, you must apply two drops of oil between the flange and the nut. *DO NOT* apply any oil to the interior threads. Follow the torquing recommendations of the manufacturer during and after installation. Avoid painting two piece flange nuts after they are installed on the wheel.



CRACKED TWO PIECE FLANGE NUTS

This condition is indicated by *ANY* crack which appears on the flange of the nut. The cause of this problem can be the result of excessive torque, damage to the nuts and/or insufficient nut strength. If this condition occurs, the nut *MUST* be replaced with the correct two piece flange nut. Inspect the wheel for cracks or damage to the mounting surface.

When installing the new flange nuts, make sure that they are designed for the application and meet the specifications of the original equipment manufacturer. Prior to installation, you must apply two drops of oil between the flange and the nut. *DO NOT* apply any oil to the interior threads. Follow the torquing recommendations of the manufacturer during and after installation. Avoid painting two piece flange nuts after they are installed on the wheel.

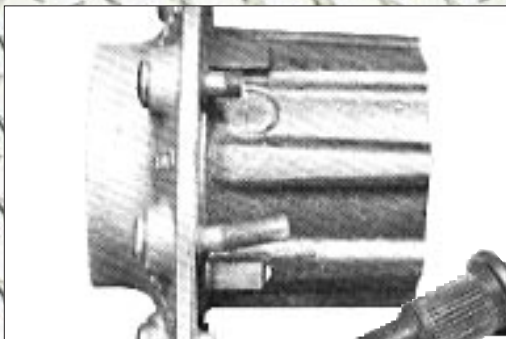

BROKEN STUDS

Broken studs are caused by either loose cap nuts or overloading or a combination of both. *IF A BROKEN STUD IS FOUND, IT MUST BE REPLACED IMMEDIATELY ALONG WITH THE STUD ON EITHER SIDE OF IT. IF MORE THAN ONE BROKEN STUD IS FOUND, REPLACE "ALL" OF THE STUDS IMMEDIATELY.*

When replacing studs, make certain that the correct stud length is used. Studs which are too long for the application will not allow the back jam nut to seat firmly against the drum resulting in a loose drum. If the stud body length or "standout" is too long, the inner wheel can not be properly secured against the hub mounting face resulting in a loose inner wheel. Also, check the actual wheel load against the manufacturer's recommended wheel load to make certain that the correct components are being used for the application.

After the proper installation of the wheel-end components, check to make certain that the proper torque is applied to each nut following the recommendations on page 12.



STRIPPED THREADS

Stripped threads are caused by the application of excessive torque. If this condition exists, the stud *MUST* be replaced following the stud installation procedure under Broken Studs - page 7.

After the proper installation of the wheel-end components, check to make certain that the proper torque is applied to each nut following the recommendations on page 12.

Proper Installation of Gunite® Hubs

1. Clean and dry all parts to be used in the installation before beginning the procedure.
2. If you are using grease lubricated wheel bearings, fill the hub with grease to the inside diameter of the outer bearing cup. Also, fill the hub cap, and pack grease between the bearing rollers, cones and cage. Use an approved, heavy-duty multi-purpose lithium base (#2 grade) grease or synthetic grease.
If you are using oil lubricated wheel bearings, skip Step 2 and proceed to Step 3.
3. Place the inner bearing in the hub, and install the seal, following the installation procedure provided by the bearing manufacturer.

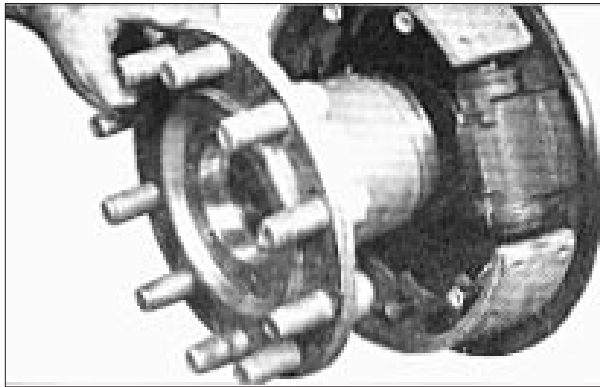

4. Install the hub by sliding it over the spindle, being careful not to damage the oil seal. Position the outer bearing over the spindle and insert it into position.

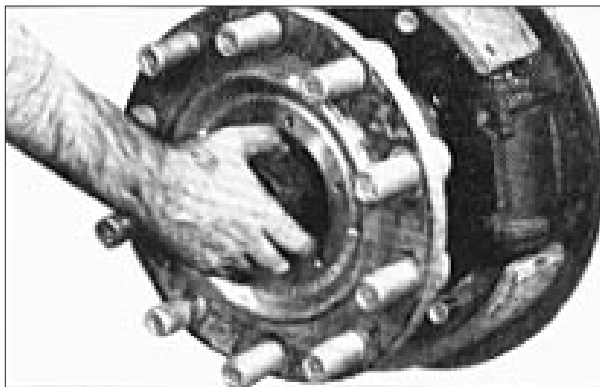

5. Install the spindle nuts following specific torquing procedures available from the individual axle, bearing, and seal manufacturer. The approved industry standard requires a minimum of 0.001" to maximum of 0.005" end play for adequate seal and bearing performance. End play should be checked after adjustment, using a dial indicator on every wheel-end.

NOTE

Never use an impact wrench to adjust wheel bearings.

6. When installing non-drive or oil lubricated wheel bearings, fill the hub to the oil level line on the hub cap. Allow time for the lubricant to pass through the outer bearing before re-checking to verify the final oil level. Check the hub cap vent hole to make certain the vent hole is clean.

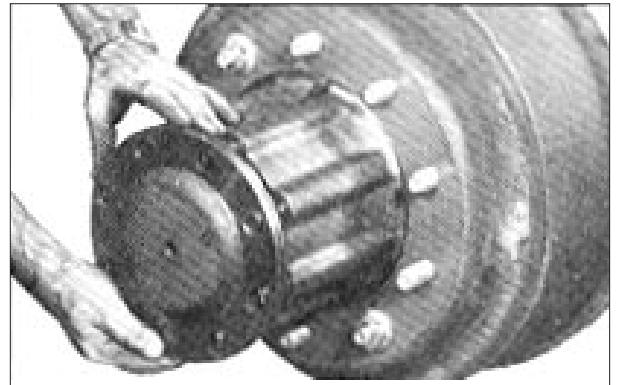

7. With drive hubs, check the oil level in the drive housing and add oil as required by the manufacturer's specifications.

When installing drive hubs, position a new gasket over the drive studs and install the axle through the hub. Use drive cones as recommended by the axle manufacturer. Torque the nuts to the manufacturer's specifications using a sequence similar to that shown on page 12.

If wheel hubs are equipped with oil fill/drain plugs, add a pint of oil to each wheel-end.

If hub do not have oil fill/drain plugs each side of the drive axle must be raised a minimum of 8" to move the lubricant into the opposite wheel-end. After you complete this procedure, re-check the oil level and top off if required.

8. For applications using an outboard mounted brake drum, the drum should now be installed onto the hub pilot positioning it over the mounting studs. Check the drum carefully to make sure that it is installing properly and seated correctly before continuing with the wheel-end assembly.

Installation of ABS Exciter "Tone" Ring onto Gunite Hubs

Gunite aftermarket or replacement hubs do not have a factory installed ABS exciter ring. The exciter ring must be ordered separately and installed on the hub before the hub is installed on the axle. To find the correct exciter ring part number and ordering information, refer to the Gunite Fleet Line parts catalog under the Service Hardware section. Locate the correct hub part number and application. Exciter rings are made of a special materials and require a specific installation procedure for proper installation. Following this procedure will allow easy and trouble-free installation of the ABS exciter ring onto the hub.

CAUTION

When installing an ABS system, special ABS hubs must be ordered. Machining of older hubs to accommodate the installation of exciter rings can cause problems due to insufficient hub bore wall thickness. Machining an older hub with insufficient hub bore wall thickness could result in cracking, causing bearing failure and possible wheel loss.

1. Heat the exciter ring by submerging it in boiling water or placing it in an oven at 250 degrees for approximately 15 minutes. **DO NOT ATTEMPT TO HEAT THE EXCITER RING WITH A TORCH AS THIS CAN DAMAGE THE RING AND CAUSE IMPROPER INSTALLATION.**

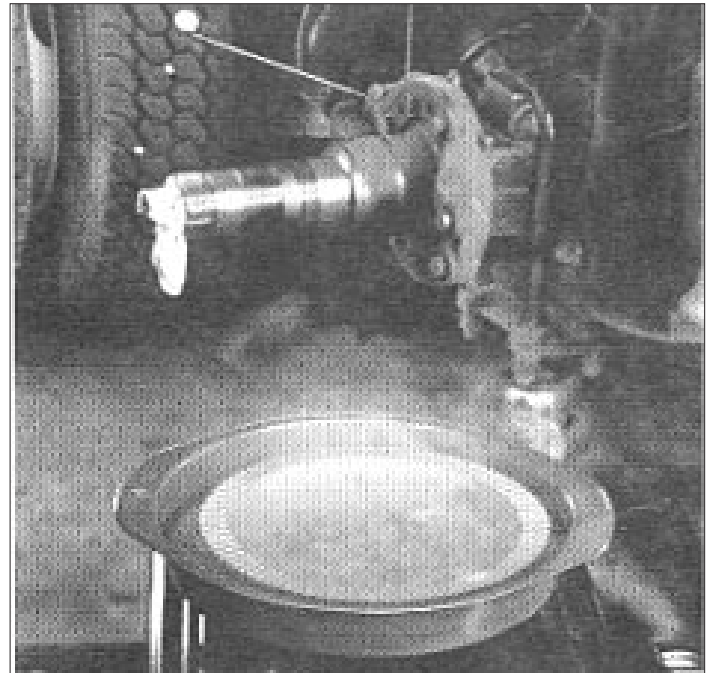

2. Using pliers, remove the exciter ring from the boiling water or oven and center it on the machined area of the hub bore.

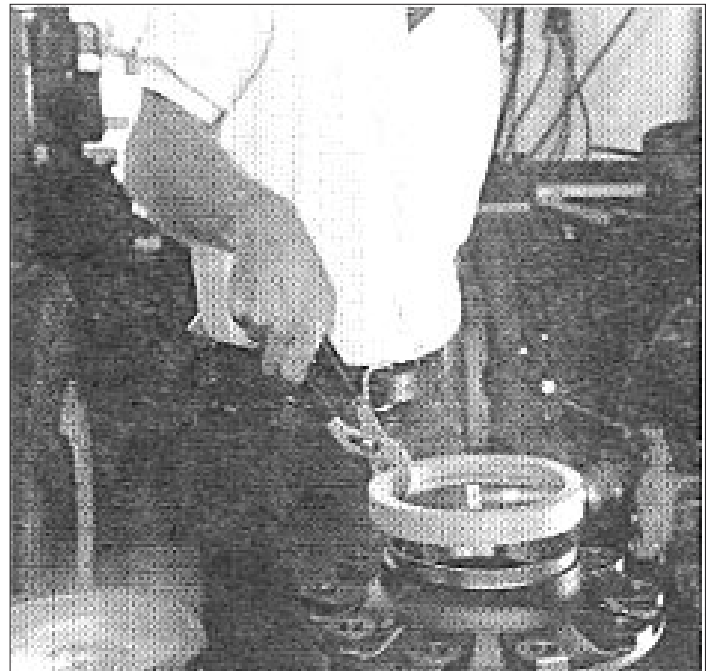

3. While the exciter ring is still hot, make sure that it is properly centered on the machined surface. Using a rubber mallet, tap the exciter ring until it bottoms out around the machined surface on the hub.



4. Check the hub to make sure that the exciter ring is properly installed. To do this, install the hub on the axle and place a dial indicator with a magnetic base so the dial indicator is against the exciter teeth.

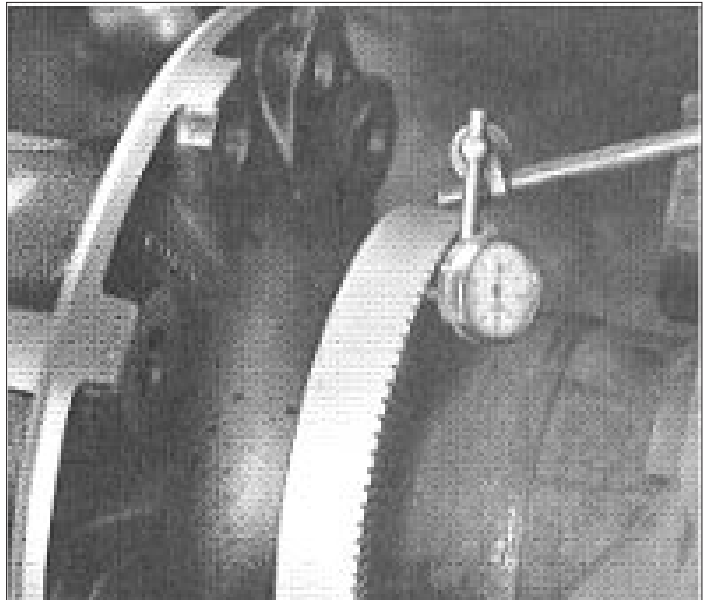

5. Rotate the hub to check the exciter teeth runout. The runout should be less than .008.

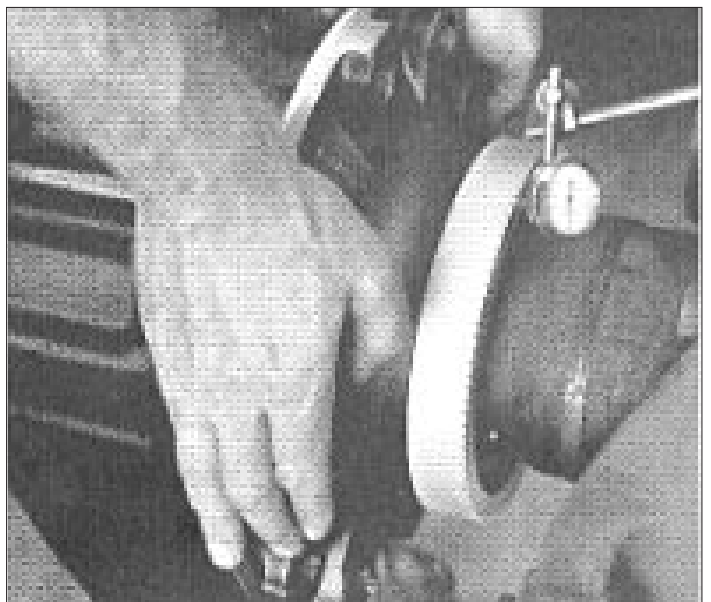

NOTE

Be advised, on vehicles with an ABS system, tone rings cannot be removed from one manufacturer's hub and installed on a hub from a different manufacturer. Tone rings are precision fit to each manufacturer's hub design and must be used only on that design. Failure to do so can result in serious accident or injury. Gunite tone rings are designed specifically for Gunite disc wheel hubs and meet stringent industry standards for quality and performance.

Proper Wheel-end Component Installation Procedures

Careless mounting is the major cause of hub, wheel and rim problems. Attention to the proper installation of the hub and wheel assemblies will help to avoid unnecessary

service problems and downtime while assuring you of maximum service life and safe operation.

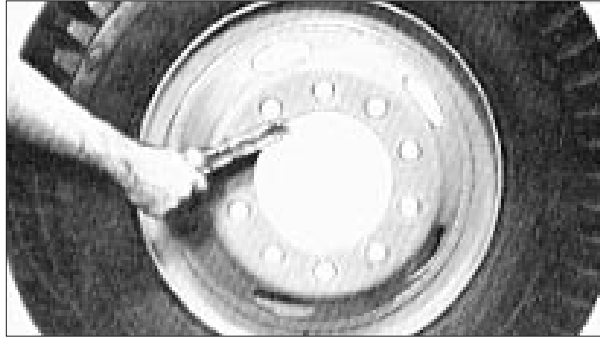

1. Before you begin the installation, check each part for damage making sure that all studs, nuts, hub and wheel mounting surfaces are clean and free from grease. Use a wire brush to clean dirt, rust, burrs, or paint off the mounting surfaces. Replace any damaged or defective parts before beginning the installation.

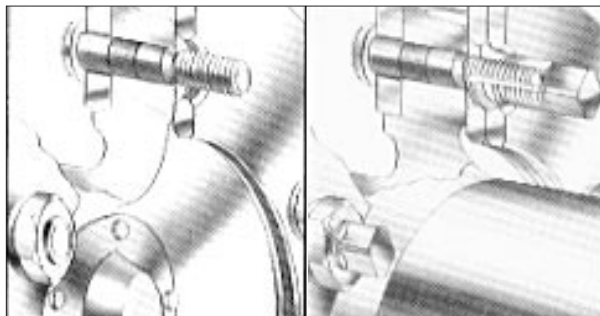

Figure 4 Single wheel installation Figure 5 Dual wheel installation

2. Mount the single or inner dual wheel over the stud, being careful not to damage any of the threads on the studs. Figure 4 illustrates how a single wheel should look when mounted. Figure 5 shows the proper mounting configuration for a dual wheel.

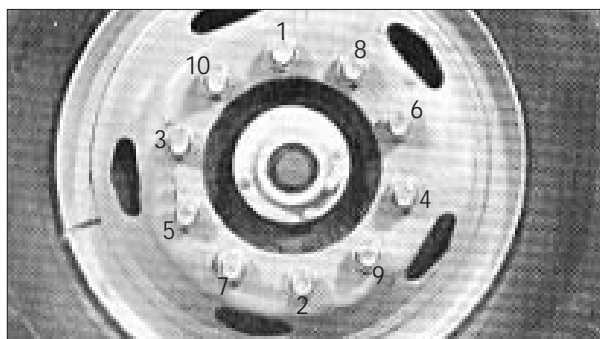

Figure 6 - Proper tightening and torquing sequence.

3. Draw up the nuts alternately in the sequence shown in Figure 6. DO NOT tighten them fully at this time. Stud and cap nut threads should be clean and dry; no oil should be used beyond the first three threads.

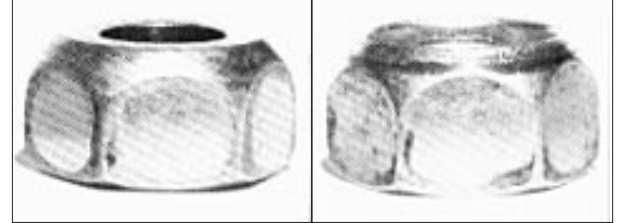

Figure 7

Figure 8

4. It is extremely important that the condition of each nut be checked before installation. Figure 7 shows a nut which is in good condition, while Figure 8 shows a cap nut which exhibits signs of scarring and galling. Any nut showing signs of damage such as the one in Figure 8, should be discarded and replaced with a new nut.

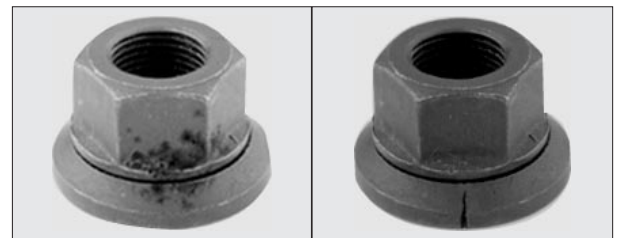
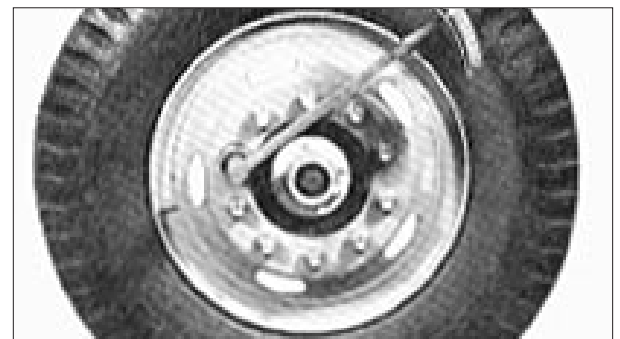

Figure 9

If two piece flange nuts are used, any nut showing excessive corrosion between the nut and the flange or any nut with a crack in the flange, as shown in Figure 9, should be discarded and replaced with a new nut.

It is also important that you have the correct fasteners. It is extremely important that various nuts are NOT interchanged or intermixed. Nuts used in a hub piloted system CAN NOT be used in a stud piloted system

Once the nuts are in place, each nut should be checked for uniform seating.



5. Tighten and torque the nuts fully, using the same alternating sequence as shown in Figure 6. Tighten them only to the recommended torque level as shown in the chart on pg. 12. Use a torque wrench to verify the proper torque, especially if an air wrench or bar wrench has been used to tighten the nuts.

Disc Wheel Mounting Torque

Mounting Type	Nut Thread	Thread Level Ft./Lb. (Oiled)*
Hub piloted with flange nut	1 1/16" - 16	300 - 400
	M20 X 1.5	280 - 330
	M22 X 1.5	450 - 500

* Apply two drops of motor oil to the point between the nut and the flange and two drops of motor oil to the last two or three threads at the end of each stud.

Mounting Type	Nut Thread	Thread Level Ft./Lb. (Dry)
Stud piloted, double cap nut standard type - 7/8" radius	3/4" - 16	450 - 500
	1-1/8" - 16	450 - 500
Stud piloted, double cap nut heavy-duty type - 1-3/16" radius	15/16" - 12	750 - 900
	1-1/8" - 16	750 - 900
	1-5/16" - 12	750 - 900

NOTE: NEVER LUBRICATE WHEEL, NUT BALL SEATS OR MOUNTING FACES. IF LUBRICATION IS DESIRED, IT MUST BE USED SPARINGLY ONLY ON THE THREADS OF THE STUDS AND/OR NUTS.

Note:

- If using specialty fasteners, consult the manufacturer for recommended torque levels.
- Tightening wheel nuts to their specified torque is extremely important. "Under" tightening will result in loose wheels which can damage the wheel, studs and hub and can result in wheel loss. "Over" tightening can damage the studs, nuts and wheels resulting in loose wheels as well.
- Regardless of the torquing method used, all torque wrenches, air wrenches or other tools used should be calibrated periodically to insure that the proper torque is applied.

WARNING

INSUFFICIENT MOUNTING TORQUE CAN CAUSE WHEEL SHIMMY, RESULTING IN DAMAGE TO PARTS AND EXTREME TIRE TREAD WEAR. EXCESSIVE MOUNTING TORQUE CAN CAUSE STUDS TO BREAK AND DISCS TO CRACK IN THE STUD HOLE AREAS.

WARNING

SOME HUB PILOTED AND STUD PILOTED WHEELS MAY HAVE THE SAME BOLT CIRCLE PATTERN AND MAY BE MISTAKENLY INTERCHANGED. CARE MUST BE TAKEN NEVER TO MIX OR INTERCHANGE PARTS BETWEEN HUB PILOTED AND STUD PILOTED WHEEL SYSTEMS. EACH MOUNTING SYSTEM REQUIRES SPECIFIC COMPONENTS TO ALLOW FOR THE PROPER MATING OF ALL COMPONENTS. IT IS IMPORTANT THAT THE PROPER COMPONENTS ARE USED WITH EACH TYPE OF MOUNTING, AND THAT THE WHEELS ARE FITTED TO THE PROPER HUBS.

IF HUB PILOTED WHEEL COMPONENTS (HUBS, DRUMS, WHEELS, FASTENERS) ARE MIXED WITH STUD PILOTED WHEEL COMPONENTS, LOSS OF TORQUE, BROKEN DRUMS, STUDS, CRACKED WHEELS AND POSSIBLE WHEEL LOSS CAN OCCUR SINCE THESE PARTS ARE NOT DESIGNED TO WORK TOGETHER.

Hub Piloted vs Ball Seat Drums

It is important to make sure that the correct hub and drum combination is used when replacing wheel-end assemblies. Incorrect or mismatched parts may result in loose or broken mounting studs or wheel-ends which can result in an accident. If you are unsure about the correct combination for your application, contact the manufacturer for the correct part numbers and styles.

Older ball seat mountings have a close fit between the drum, the stud holes and stud diameter. The drum is installed on the hub pilot. The wheels are piloted on the studs using inner and outer cap nuts. (see Figure 10)

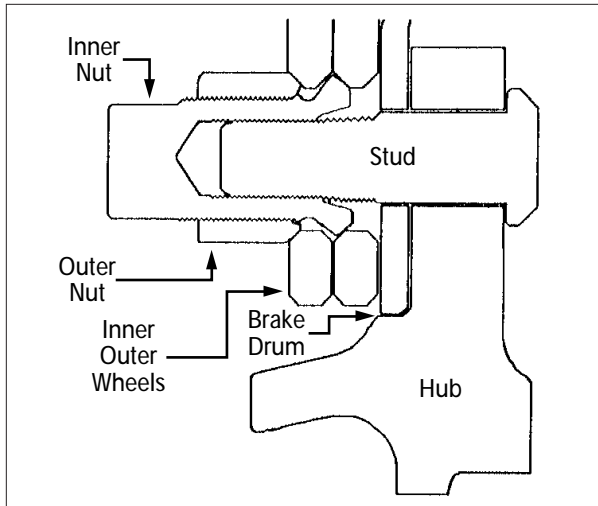

Figure 10 - A ball seat disc wheel mount

Hub piloted mountings have a close fit between the drum pilot and the machined pilot (continuous or interrupted) on the hub. The drum bolt mounting holes are larger than the stud diameter. The wheels and drum are piloted on the hub. (see Figure 11)

New drum designs will allow you to use the same drum for ball seat and hub piloted applications when matched with the proper hub. These new drums cannot be used with older hubs which have a different pilot diameter. Matching the drums with the proper hub is critical in providing and maintaining the support of the wheel-end.

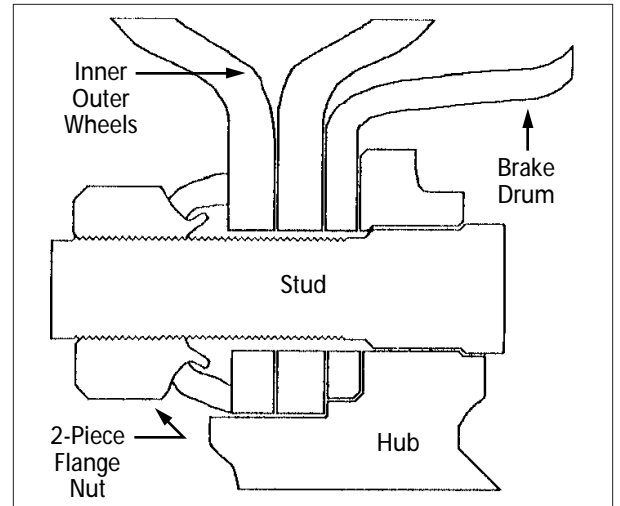
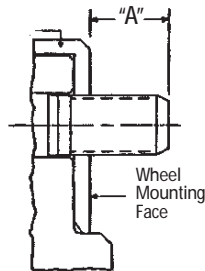

Figure 11 - A hub piloted disc wheel mount.

Stud Standout

When changing studs or hubs, it is important to have the correct stud standout to insure proper wheel mounting. Stud standout appears as dimension "A" in the two diagrams below.

Outboard Drum Mounting



Inboard Drum Mounting

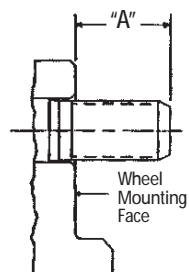

Ball Seat Mounting Applications

(All dimensions in inches)

Numbers of Studs	Bolt Circle Diameter	"A" Dimension	
		Ferrous Wheel	Aluminum Wheel
6	8.75	Single 1.25 min. Dual 1.31 - 1.44	Single 1.50 min. Dual 1.31 - 1.44
10	8.75	Single 1.25 min. Dual 1.31 - 1.44	— —
10	11.25	Single 1.25 min. Dual 1.31 - 1.44	Single 1.68 min. Dual 1.31 - 1.44

I.S.O Metric (Hub Piloted) Applications

(All dimensions in mm)

Numbers of Studs	Bolt Circle Diameter	"A" Dimension	
		Ferrous Wheel	Aluminum Wheel
8	275	Single 48 Dual 62	Single 54 Dual 79
10	285.75	Single 48 Dual 62	Single 59 Dual 84
10	335	Single 48 Dual 62	Single 59 Dual 84

Special Considerations For Aluminum Hubs

Some applications may incorporate the use of aluminum hubs. While the general installation and maintenance procedures are relatively the same for aluminum hubs as those used for cast iron hubs, special care and attention must be taken when installing or servicing aluminum hubs

in order to provide reliable over the road performance and normal service life. Read and follow all instructions provided by the manufacturers of aluminum hubs. The following areas are especially important considerations in the use and maintenance of aluminum hubs.

Clean the Assembly Thoroughly

Aluminum has a natural resistance to normal corrosion and does not need to be painted for most operating conditions. Certain operating environments such as salt, chloride compounds, high alkaline materials or severe applications such as livestock hauling, can create unusual amounts of corrosion. In these cases, greater care must be taken in the cleaning of the hub/wheel assembly to insure normal service life and performance.

The outer surface should be cleaned with a mild detergent using steam or high-pressure water to remove built-up dirt and grime. When the tires are removed, the entire assembly should be cleaned and inspected for wear or damage. A wire brush or steel wool can be used to remove any remaining soil or oxidation. Special attention should be



given to cleaning ALL corrosion from the pilot areas to allow for proper installation of the wheel-end assembly.

Avoid Abuse

Aluminum hubs offer advantages in weight savings, but extra care must be taken to protect them from damage during operation. Careless handling during tire changes, striking with hammers or other metal objects can damage the mounting surface of the hub resulting in the inability to correctly mount the wheel-end assembly. Caution must be exercised when driving to avoid hitting curbs at high speeds or at sharp angles which can also damage aluminum hubs.

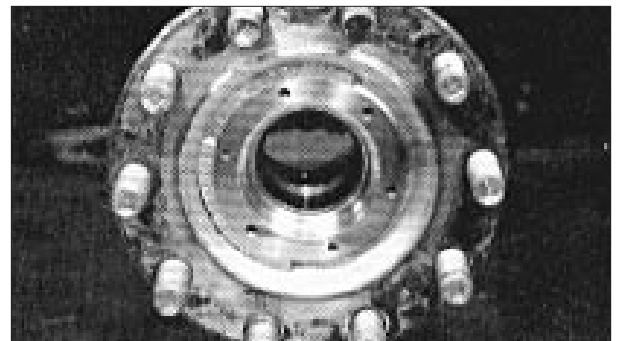

Keep Cap Nuts Tight

While the torque requirements for aluminum hubs are different than those for cast iron hubs, maintaining proper tightness is equally important for both. **NOTE: DO NOT OIL NUTS USED IN CONJUNCTION WITH ALUMINUM HUBS.**

Final torquing of the cap nuts should be done alternately in the sequence shown to the right.

The seats of the cap nuts used for aluminum hubs are precision-machined spherical surfaces. **NEVER USE CAP NUTS WITH CONE SEATS.** They will cause uneven pressure, damage to the hub/wheel assembly, cause loose wheels and may result in fractures (follow torquing sequence on page 12).



Mounting Nut Installation Torque

Nut Type	Wheel Stud Thread Size	Torque Ft./Lb. (Dry)
Ball Seat		450 - 500
Two Piece Flange Nuts	M22 X 1.5	400 - 500
	M20 X 1.5	280 - 330

NOTE: NEVER LUBRICATE WHEEL, NUT BALL SEATS OR MOUNTING FACES. IF LUBRICATION IS DESIRED, IT MUST BE USED SPARINGLY ONLY ON THE THREADS OF THE STUDS AND/OR NUTS.

Bearing Cup Replacement for Aluminum Hubs

The replacement of bearing cups in aluminum hubs requires you to follow a certain procedure. Following this procedure will insure the proper installation of the bearing cup without damage to the aluminum hub.

1. Remove the wheel(s) from the hub.
2. Remove the outboard-mounted brake drum (if applicable).
3. Remove the hub from the axle spindle.
4. Remove the inboard-mounted brake drum or disc brake rotor from the hub (if applicable).
5. Carefully remove the seal and bearing cone from the hub making sure that no damage is done to the seal bore.
6. Thoroughly clean and degrease the hub with a non-flammable solvent.
7. Place the hub in an oven, heating evenly throughout to a temperature of 175 - 200 degrees F.

WARNING

DO NOT use oxy-acetylene or similar equipment to heat the hub. This may cause overheating in localized areas which will result in loss of strength that may cause failure of the hub assembly and ultimately loss of vehicle control.

10. Remove the hub from the oven. Properly align the new bearing cup and quickly press into place. Make sure that the new bearing cup is properly seated. Care must be taken to avoid damaging the bearing cup bore or the shoulder.

NOTE: Variations in the tolerance of materials and oven temperatures may allow bearing cup to drop in easily.

WARNING

If the hub is damaged during the process, it must be replaced. Using a damaged hub on a vehicle could result in hub failure and ultimately in the loss of vehicle control.

8. Remove the hub from the oven, and quickly press out the old bearing cup. Care must be taken to avoid damaging the bearing cup bore or the shoulder.

NOTE: Variations in the tolerance of materials and oven temperatures may allow bearing cup to drop out easily.

9. Place the hub back in an oven, heating evenly throughout to a temperature of 175 - 200 degrees F.

11. Assemble the inboard-mounted drum or disc brake rotor onto the hub (if applicable). Follow the assembly instructions on page 11 using the torque values above.
12. Install the hub onto the axle spindle following the instructions on page 8.
13. Assemble the outboard-mounted drum (if applicable) and disc wheel(s) onto the hub following the assembly instructions on page 11 using the torque values above.

Check the Hubs on New Equipment

When taking delivery of new equipment which uses disc wheels, there are three steps that need to be taken to

insure that your equipment is suited to your application and that it will perform safely during the normal operation.

Verify Hub Load Rating

It is important to verify the hub load rating on new equipment to make sure that it will satisfy the actual load capacity requirements. Some operators install greater capacity tires to increase the payload. This does not increase

the load rating of the hubs. Operating your equipment under extreme conditions or with loads greater than the rated capacity of the hubs may cause damage to the hub and affect vehicle performance.

Check The Mounting Nut Torque

After the new truck, tractor or trailer has traveled the first 50 to 100 miles, the hub/wheel assembly will "seat", causing the mounting nuts to lose some of their initial torque. In order to assure proper and safe operation, the following procedure *MUST* be followed.

If two piece flange nuts are used, re-torque to the proper values as shown on page 12.

If cap nuts are used, proceed using the following three step procedure.

1. Loosen the outer cap nuts.

2. Tighten the inner cap nuts to the proper torque as shown in the torquing chart on page 12.
3. Retighten the outer cap nuts to the proper torque as shown in the torquing chart on page 12.

If this procedure is followed as recommended, the cap nuts should not lose torque during normal operation. It is still necessary for the cap nuts torque to be checked regularly as part of a complete preventative maintenance program.

Establish a Good Preventative Maintenance Program

Establishing a good preventative maintenance program will insure that your equipment performs efficiently and safely. Familiarize your operators and service personnel with the

guidelines and procedures recommended in this manual as part of that regular maintenance program.

WARRANTY

Gunite Corporation warrants to the original purchaser that its spoke wheels, hubs, brake drums and brake rotors are free from defects in material and workmanship. Gunite Corporation agrees to repair or replace, without charge, any and all of its products which fail in normal use and service because of defects in material and/or workmanship.

Gunite Corporation shall not be liable for any incidental or consequential damages for any breach of warranty, its liability and the purchaser's exclusive remedy being expressly limited to repair or replacement of the product as herein provided. There are no other warranties, expressed or implied except such as is set forth herein.



GUNITE CORPORATION
302 Peoples Ave. ■ Rockford, IL 61104-7092
Phone (815) 964-3301 ■ Toll-Free (800) 677-3786 ■ Fax (815) 965-9197